

Towards quantification of hidden corrosion using D-Sight non-destructive testing technique

Andrzej Katunin

Silesian University of Technology, Faculty of Mechanical Engineering, Department of Fundamentals of Machinery Design, Konarskiego 18A, 44-100 GLIWICE, Poland (andrzej.katunin@polsl.pl) ORCID [0000-0002-9386-5104](https://orcid.org/0000-0002-9386-5104)

Krzysztof Dragan

Air Force Institute of Technology, Division of Airworthiness, Ks. Bolesława 6, 01-494 WARSAW, Poland (krzysztof.dragan@itwl.pl) ORCID [0000-0003-1857-227X](https://orcid.org/0000-0003-1857-227X)

Marko Nagode

University of Ljubljana, Faculty of Mechanical Engineering, Aškerčeva c. 6, 1000 LJUBLJANA, Slovenia (marko.nagode@fs.uni-lj.si) ORCID [0000-0003-0637-3812](https://orcid.org/0000-0003-0637-3812)

Krzysztof Lis

Silesian University of Technology, Department of Machine Technology, Konarskiego 18A, 44-100 GLIWICE, Poland (krzysztof.lis@polsl.pl) ORCID [0000-0003-0785-0553](https://orcid.org/0000-0003-0785-0553)

Kamil Jozsko

Silesian University of Technology, Department of Biomechanics, Roosevelta 40, 41-800 ZABRZE, Poland (kamil.jozsko@polsl.pl) ORCID [0000-0002-8229-3032](https://orcid.org/0000-0002-8229-3032)

Adam Cholewa

Silesian University of Technology, Faculty of Mechanical Engineering, Department of Fundamentals of Machinery Design, Konarskiego 18A, 44-100 GLIWICE, Poland (adam.cholewa@polsl.pl) ORCID [0000-0002-0040-6823](https://orcid.org/0000-0002-0040-6823)

Jernej Klemenc

University of Ljubljana, Faculty of Mechanical Engineering, Aškerčeva c. 6, 1000 LJUBLJANA, Slovenia (jernej.klemenc@fs.uni-lj.si) ORCID [0000-0002-6778-6728](https://orcid.org/0000-0002-6778-6728)

Simon Oman

University of Ljubljana, Faculty of Mechanical Engineering, Aškerčeva c. 6, 1000 LJUBLJANA, Slovenia (simon.oman@fs.uni-lj.si) ORCID [0000-0001-8213-0818](https://orcid.org/0000-0001-8213-0818)

Paweł Żak

Silesian University of Technology, Faculty of Mechanical Engineering, Department of Fundamentals of Machinery Design, Konarskiego 18A, 44-100 GLIWICE, Poland (pawezak456@student.polsl.pl)

Piotr Synaszko

Air Force Institute of Technology, Division of Airworthiness, Ks. Bolesława 6, 01-494 WARSAW, Poland (piotr.synaszko@itwl.pl) ORCID [0000-0002-7884-0582](https://orcid.org/0000-0002-7884-0582)

Author Keywords

D-Sight, hidden corrosion, aircraft structures, non-destructive testing.

Type: Research Article

Abstract

Hidden corrosion, not detected timely, may significantly affect the durability and integrity of aircraft structures; therefore, improvement of non-destructive testing (NDT) techniques is of high importance for reliable and safe aircraft operation. One of the commonly used NDT techniques for the detection of such a type of corrosion is the D-Sight technique, which gained wide appreciation in the aerospace sector due to its ability to perform low-cost and fast inspections of wide areas. One of the drawbacks

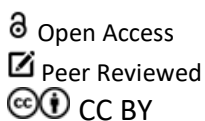

of the method is its qualitative character, which makes it difficult to quantify corroded spots and track corrosion growth during operation. The following study aims to present recent advances in the enhancement of this technique by using advanced image processing, numerical simulations, and validation studies using reference methods (classical metrology, and digital image correlation) to make this method suitable for quantification of areas affected by hidden corrosion and monitoring its growth between periodic NDT inspections. The studies are performed on test specimens that simulate hidden corrosion and verified on results of D-Sight inspections of the Polish Air Force military aircraft. The results demonstrated good performance in identification and quantification hidden corrosion spots on D-Sight images. The approach can be used for supporting aircraft inspectors in analysis of inspection results of aircraft under operation that require periodic non-destructive testing.

1. Introduction

Aircraft structures are subject to aging processes, which is evidenced by the appearance and propagation of various types of damage, in particular, corrosion. The appearance of corrosion in aircraft structures remains a major problem with the highest maintenance cost, which is placed at the level of \$20 billion annual expense for the US Department of Defense only ([Sajedi 2019](#); [Benavides 2009](#)). This implicated advanced studies in the development of appropriate materials and coatings that are prone to corrosion and numerous environmental factors that may influence its acceleration of development. Regardless of this, metallic aircraft structures require periodic inspections to evaluate their condition, to detect possible damage and timely react on the structural weakening. According to the widely accepted damage tolerance design and maintenance philosophy, such inspections are the key factor in ensuring structural integrity and safety in aviation. For this purpose, periodic inspections are performed using non-destructive testing (NDT) techniques ([Nechval et al. 2011](#), [Grandt Jr. 2011](#)).

From the variety of available NDT techniques, only a part of them are approved for inspections of aircraft structures by appropriate national and international authorities, since they represent valid and repeatable inspection results ([FAA 1998](#)). They include numerous advanced techniques, which require special equipment and certified personnel and provide a possibility of detecting and identifying damage to the undersurface ([Wronkowicz-Katunin 2018](#)). An overview of the NDT techniques most often used for the inspection of aircraft structures with an analysis of their suitability for detecting specific types of damage can be found ([Towsyfyfan et al. 2020](#)).

Numerous types of corrosion affect aircraft structures, depending on the materials used for their production and the conditions of their operation. These types include general attack, pitting, galvanic, crevice, erosion, corrosion fatigue, stress corrosion cracking, hydrogen embrittlement, and many others ([Mills et al. 2009](#); [Czaban 2018](#); [Katunin 2019](#)). However, one of the corrosion types, namely pillowing or hidden corrosion, is not well described in the literature, and, compared to overall research on corrosion in aircraft structures, not much information is available on this type of corrosion as well as methods of its evaluation. Hidden corrosion usually appears in elements and components of the aircraft fuselage, mainly in lap joints ([Bellinger et al. 2007](#)), but also in other airframe structures ([Forsyth and Lepine 2002](#)), such as multilayer skins. This type of corrosion is manifested by local bulging of the material around the rivets that connect the metal sheets. The occurrence of this type of corrosion is

typical for aluminum alloys used for elements of aircraft fuselage, in particular, due to seal damage in lap joints. The mentioned bulging is the result of the expansion of corrosion products in the joint, leading to local deformations, but they are so tiny that they are not visible on the surface by the naked eye (Agarwala and Ahmad 2000). Naturally, these deformations cause structural weakening and their appearance in the vicinity of the rivets further increases the seriousness of the probability of structural failure (Czaban 2018). Therefore, it is important to detect and identify hidden corrosion spots in a timely manner and to apply preventive measures to ensure structural safety.

In the inspection of aircraft structures for corrosion detection numerous NDT techniques are used. They include ultrasonic testing, eddy current testing, infrared thermography, radiography, X-ray computed tomography, etc. (Kant et al. 2019; Ciężak and Rdzanek 2020). Many of the mentioned techniques are not applicable or are not sensitive enough to detect hidden corrosion. For example, eddy current testing is biased by significant uncertainty, since thinning of a metal sheet caused by hidden corrosion is on the level of manufacturing tolerances of this metal sheet, and the evaluation of the presence of corrosion based on the thickness of a metal sheet is not effective (Komorowski et al. 1997). This problem can be overcome by using the optical NDT technique called double pass retroreflection or simply D-Sight. This technique was developed by Diffracto Ltd. in 1983 in Canada and was further implemented in the Canada IAR NRC (Institute for Aerospace Research, National Research Council) for the inspection of aircraft structures with a dedication to hidden corrosion and barely visible impact damage detection (Hegeniers 1993).

The D-Sight technique is based on illumination of an inspected surface with a light source at a specific oblique angle. The light is further backpropagated from the special retroreflective screen in the testing system made as a grid of small spherical glass elements (Hegeniers 1993). The response is recorded by a camera as a digital grayscale image. Until the inspected structure is flat, the distribution of light intensity remains uniform (Hegeniers 1993). However, when deformations are present on the inspected surface, it is manifested by local disturbances of light intensity, which, in turn, resulting in changes of brightness contrast in the resulting D-Sight image (Hegeniers 1993). This technique found application primarily in the inspection of aircraft structures (Bellinger et al. 2007; Forsyth and Lepine 2002; Komorowski et al. 1997; Reynolds et al. 1993; Bellinger et al. 2001) but also in the automotive industry (Hegeniers 1993), and several others.

Despite the great performance of the D-Sight technique, its main deficiencies are sensitivity to measurement conditions, such as angle of observation and illumination, as the well as qualitative character of the results of inspection. The solution to the first mentioned problem was proposed in previous studies of the authors (Katunin et al. 2022; Katunin and Dragan 2022), while the second problem, although studied by numerous authors, remains open. The studies of the discoverers of the technique were focused mainly on the application of the finite element (FE) model for the quantification of corrosion (Bellinger et al. 2007; Komorowski et al. 1997; Bellinger et al. 2001; Komorowski et al. 1996), and demonstrated relatively good performance of this approach. Nevertheless, its practical application is limited due to the necessity of developing an FE model. The quantitative evaluation remains the desired capability of D-Sight technique, which will be applicable in practice by direct analysis of acquired D-Sight images from the inspection system. The first results demonstrate capabilities of the quantitative evaluation of corrosion spatial extent directly from the processing of D-Sight images (Katunin et al. 2023).

In the current study, an approach based on image processing to retrieve quantitative diagnostic information directly from D-Sight images was investigated and the results were validated using reference methods. The following paper demonstrates the concept of the developed quantification approach with the case study performed on D-Sight images from military aircraft, summarize recent results on validation of the developed approach and draw further directions and possibilities of development of the approach towards quantification of hidden corrosion directly from D-Sight images.

2. The Concept of Quantification of Hidden Corrosion Extent

Inspections performed using the D-Sight technique are based on the acquisition of grayscale D-Sight images of an inspected surface, making it possible to evaluate the severity of hidden corrosion based on the color intensity observed in the resulting D-Sight images. Usually, such an evaluation is performed manually and subjectively based on observed differences in local brightness contrast, mainly in the surrounding of rivets on the inspected aircraft structure. In some cases, the D-Sight index D proposed by Heida and Bruinsma (Heida and Bruinsma 1998) is used for evaluation of corrosion severity and its evolution (Leski et al. 2006):

$$D = 100 \cdot \frac{I_{\max} - I_{\min}}{I_{\max} + I_{\min}} \quad (1)$$

where I_{\max} and I_{\min} represent maximal and minimal image brightness values in the analyzed area. However, this measure also has subjective character. In the case of routine inspections, when the number of acquired images is great, such evaluation is difficult and non-repeatable, which makes it impossible to accurately evaluate and track corrosion severity over the years of operation of an inspected structure. Due to this, the D-Sight technique is used mainly as a preliminary inspection tool.

To overcome this shortcoming, the processing algorithm for D-Sight images was developed and proposed by Katunin et al. (Katunin et al. 2022). The algorithm consists of three major steps: initial processing, segmentation, and post-processing with evaluation. The concept of a processing algorithm for a sequence of historical D-Sight images is presented on the flowchart in Figure 1.

The above-presented approach makes it possible to determine the exact dimensions of spatial extent of hidden corrosion or other type of damage detectable with the D-Sight technique knowing the reference dimensions (e.g., spatial dimensions of a tested structure, specific distances between characteristic construction elements, like joints). This extends the capabilities of the technique and makes it possible to perform spatial identification of hidden corrosion using raw results of D-Sight inspections only.

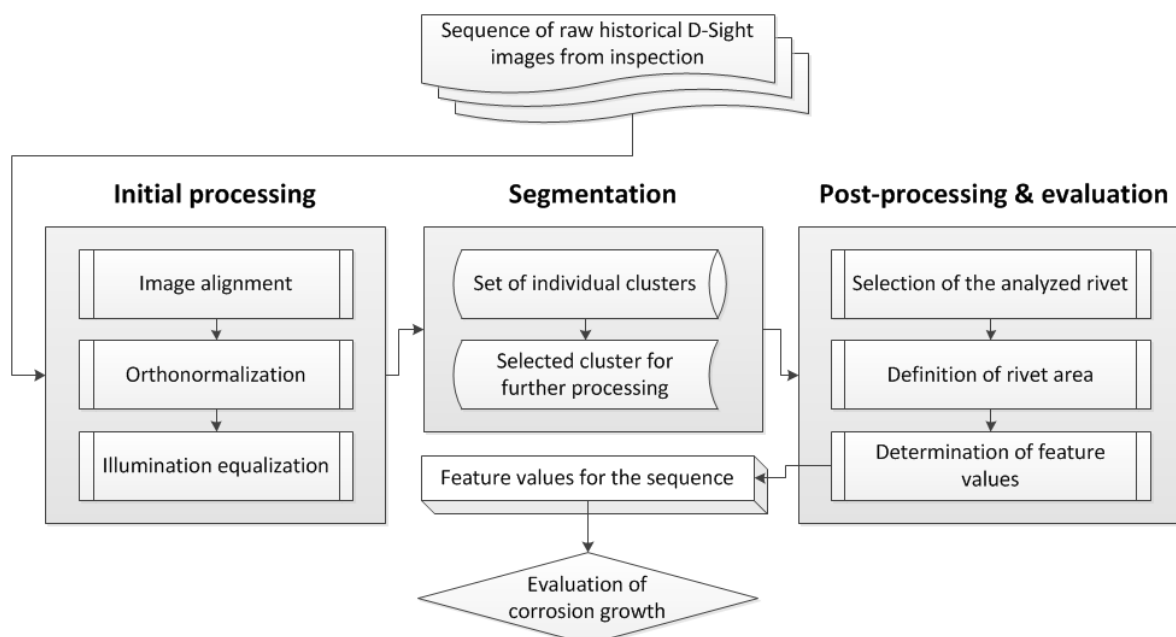

Figure 1: The flowchart of processing D-Sight images for a quantification of hidden corrosion extent (Katunin et al. 2022)

3. Case Study

To demonstrate the capabilities of the proposed approach, the case study is presented in this section using the real inspection data of the fuselage plating of military aircrafts of the Polish Armed Forces.

3.1. Tested Structure and Inspection

The inspection was performed on the skin of a military aircraft made of aluminum alloy with riveted joints using the D-Sight technique. The presence of hidden corrosion is manifested by the local changes in the brightness contrast observable around the rivets (see Figure 2(a)). The inspection was carried out using the DAIS (D-Sight Aircraft Inspection System) 250C commercial scanning system manufactured by Diffracto Ltd., Windsor, ON, USA. The field of view of this system is 580×131 mm, and the resolution of the resulting D-Sight 8-bit image is 640×480 pixels. The scanning process using DAIS is presented in Figure 2(b).

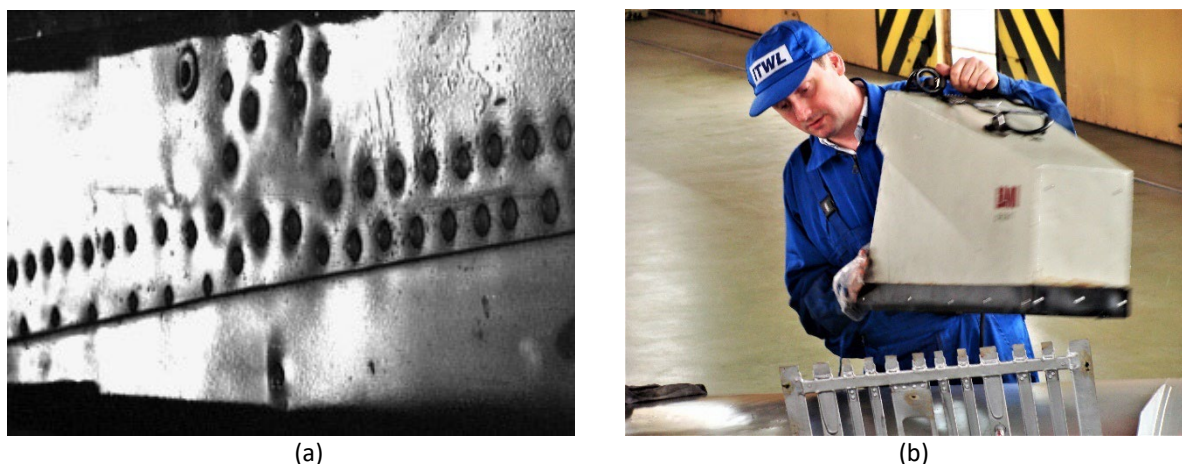

Figure 2: (a) the exemplary D-Sight image with hidden corrosion spots, and (b) the process of D-Sight inspection of an aircraft

3.2. Processing of the D-Sight Image

The D-Sight image presented in [Figure 2\(a\)](#) was subjected to processing according to the algorithm presented in [Figure 1](#), which was implemented in MATLAB environment. Initially, the image was aligned to prepare it for definition of the reference points for the next processing steps. At this step, the alignment was performed in such a way that the selected edge was made parallel to one of the edges of the processed D-Sight image. The alignment was implemented by using Canny method for edge detection and then the Hough transform to find the lines in principal directions of the image. Further, the orthonormalization algorithm was applied to turn the image into a planar projection, which is necessary for evaluating corrosion spots at the post-processing step. The orthonormalization was performed by the definition of a quadrangle on the specific points of the D-Sight image and determination of the projective transformation matrix. Finally, illumination equalization was applied to improve the visibility of corrosion spots and prepare the image for segmentation. This procedure was implemented by using a transformation which is using cumulative histograms and intensities of particular histogram components. The results of these operations are presented in [Figure 3](#).

In the next step, the D-Sight image after initial processing was subjected to segmentation using the specially developed segmentation algorithm within the Rebmix R package ([Nagode et al. 2022](#)) based on the univariate three-parameter Gumbel finite mixture model and the Bayes decision theory. This approach made it possible to extract clusters with appropriate visibility of rivets with hidden corrosion from the initially processed D-Sight image. The obtained probability density function and the Bayesian information criterion variability is presented in [Figure 4](#). The acquired clusters were then merged based on the entropy rule, which made it possible to select appropriate clusters containing useful information for further analysis.

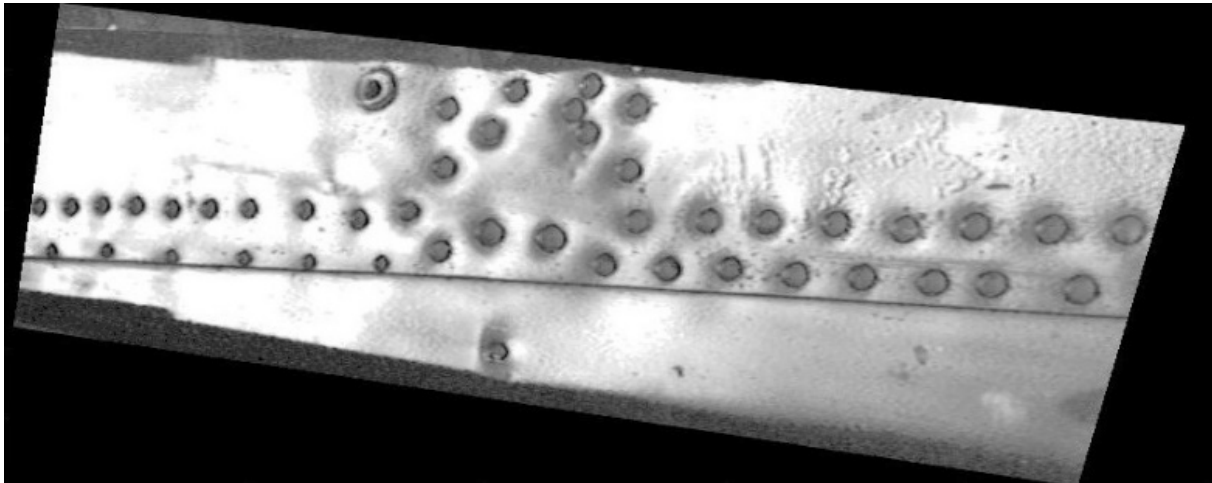

Figure 3: The D-Sight image after initial processing

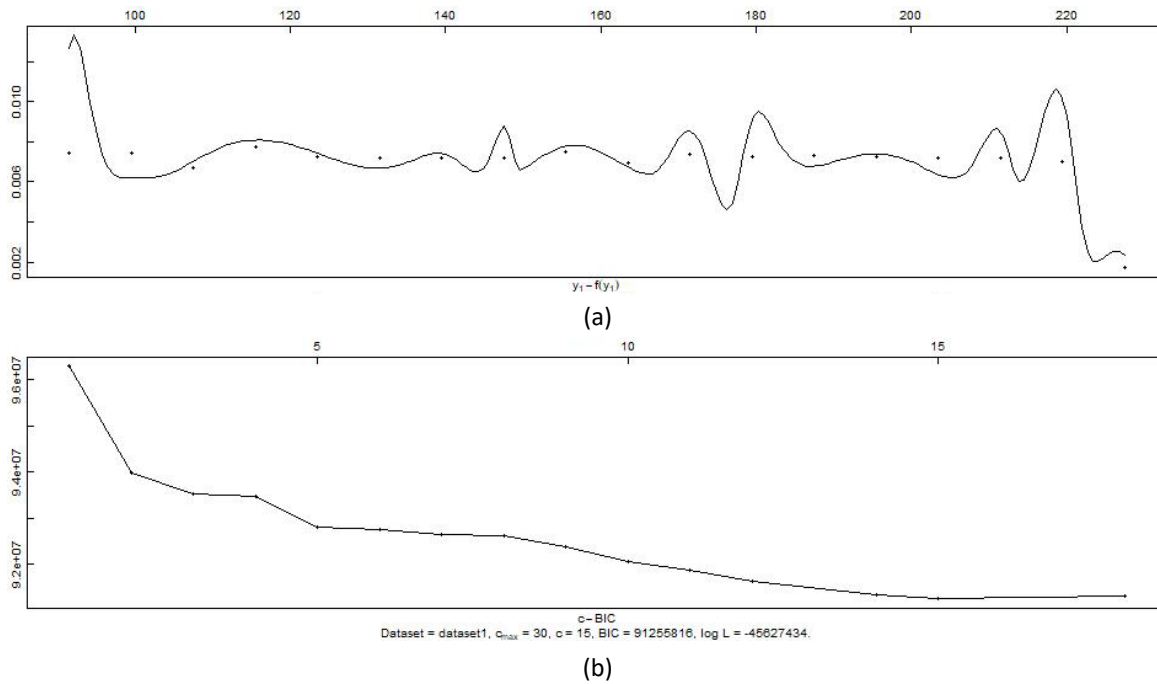

Figure 4: (a) probability density function and (b) Bayesian information criterion for the segmented D-Sight image

From the clusters obtained after segmentation, the first one was selected as the most suitable to represent hidden corrosion in the analyzed image. This cluster is presented in Figure 5. It can be observed that the corrosion spots are properly captured during segmentation.

The resulting image was used for the last step of post-processing and evaluation. At this step, the rivet to be analyzed is manually selected from the segmented D-Sight image (see Figure 6(a)), and after selection of the region of interest (ROI), the center of the given rivet within this region and its radius are determined (see Figure 6(b)). Knowing the size of the rivet, it is possible to assess the extent of the corrosion or present it in a dimensionless way. In the analyzed case, the area of the hidden corrosion extent is 95% with respect to the area of the selected rivet.

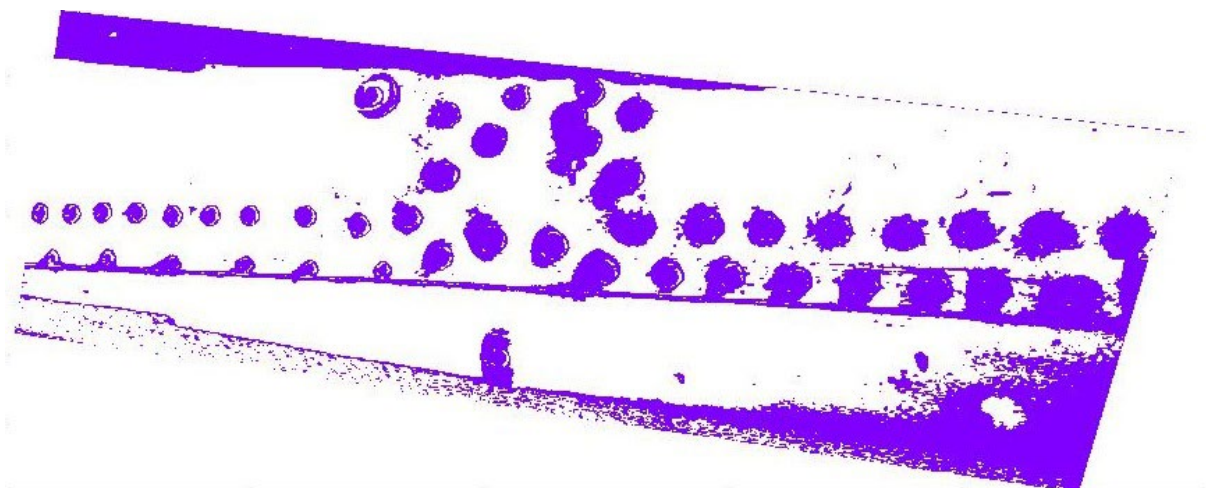

Figure 5: The selected cluster representing the hidden corrosion in the D-Sight image

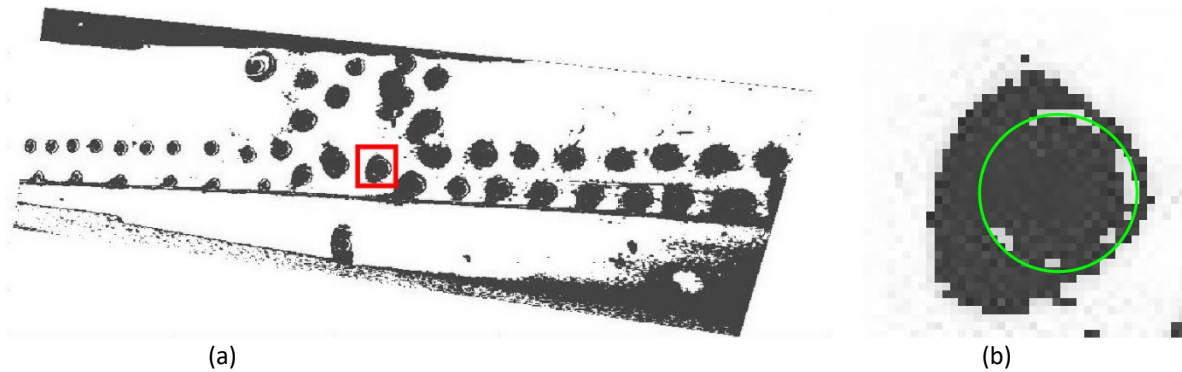

Figure 6: (a) the processed D-Sight image with ROI, and (b) the result of evaluation of hidden corrosion extent around the rivet

This example demonstrates the performance of hidden corrosion evaluation and can be automated to evaluate corrosion in multiple locations, as well as track corrosion progression by analysis of D-Sight images from periodic NDT inspections (Katunin et al. 2022).

4. Recent Progress in Damage Quantification using D-Sight Technique

Although the processing algorithm makes possible the quantitative evaluation of hidden corrosion, it is necessary to validate the results of the D-Sight technique itself to ensure the accuracy of determination of the corrosion extent. For this purpose, several numerical and experimental investigations were planned.

4.1. Numerical Simulations

The modeling approach to assess the severity of corrosion based on numerical simulation of the deformations resulting from the pillowing effect was described by Komorowski et al. (Komorowski et al. 1997; Bellinger and Komorowski 1997). This approach was adapted by the authors to perform such an evaluation. The simulation was performed in ANSYS 2022 R1 commercial software. The prepared model was defined in the form of a sheet with the thickness of 1.14 mm made of aluminum 2024 T3 alloy. The model contained nine holes at which fixed boundary conditions were defined. These holes simulate riveted joints in the simulated sheet. Then a test pressure loading of 1 MPa was applied to one of the surfaces of the simulated sheet and the geometrical model was meshed with hexagonal elements (see Figure 7(a)). In the next step, static structural analysis was performed for the defined parameters (see exemplary results in Figure 8) and the resulting model with deformed sheet was exported to computer-aided design (CAD) model. Based on this model, the evaluation of the volume under the deformed sheet was performed in the Autodesk Fusion 360 commercial software. By positioning the symmetry planes of the deformed model and the model without deformation, it was possible to evaluate the volume under the deformed sheet (see Figure 7(b)). Based on these calculations, it was possible to determine deformations for the predefined corrosion severities (Żak 2022).

The analyzes were performed for various thickness values of sheets, namely 1.14 mm, 2.06 mm, and 3.66 mm, for which the test pressure was empirically determined. After rounding, the following values were applied: 1 MPa, 7 MPa, and 50 MPa, respectively. Moreover, three severities of corrosion were considered, that is, 5%, 10%, and 15%. The results of the calculations for the mentioned cases are presented in Table 1.

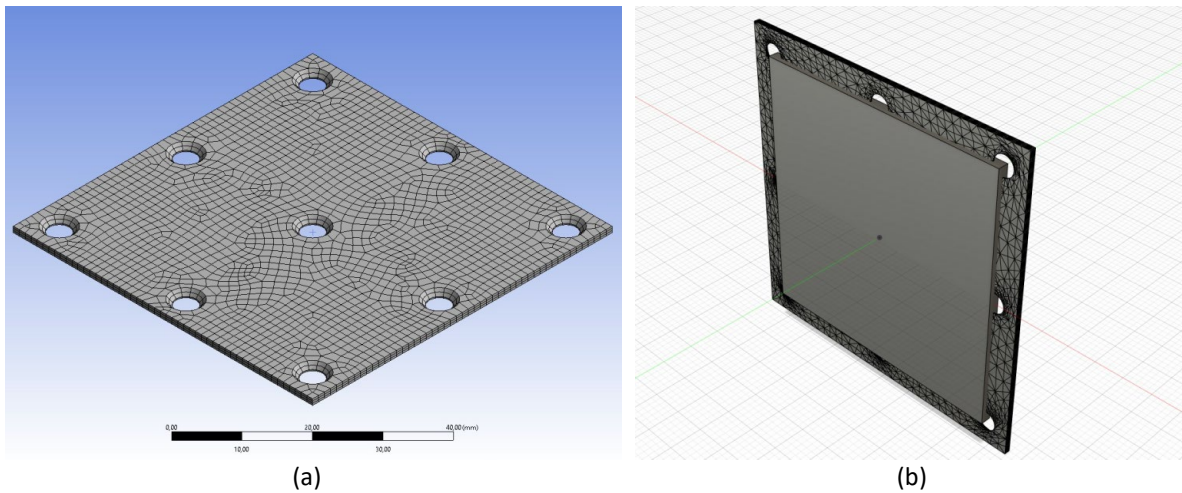
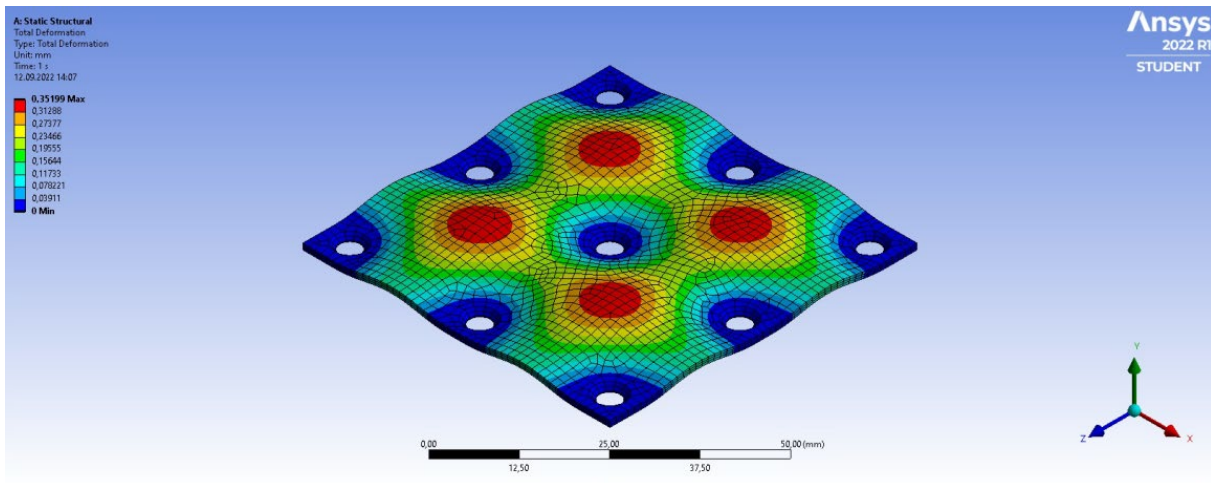
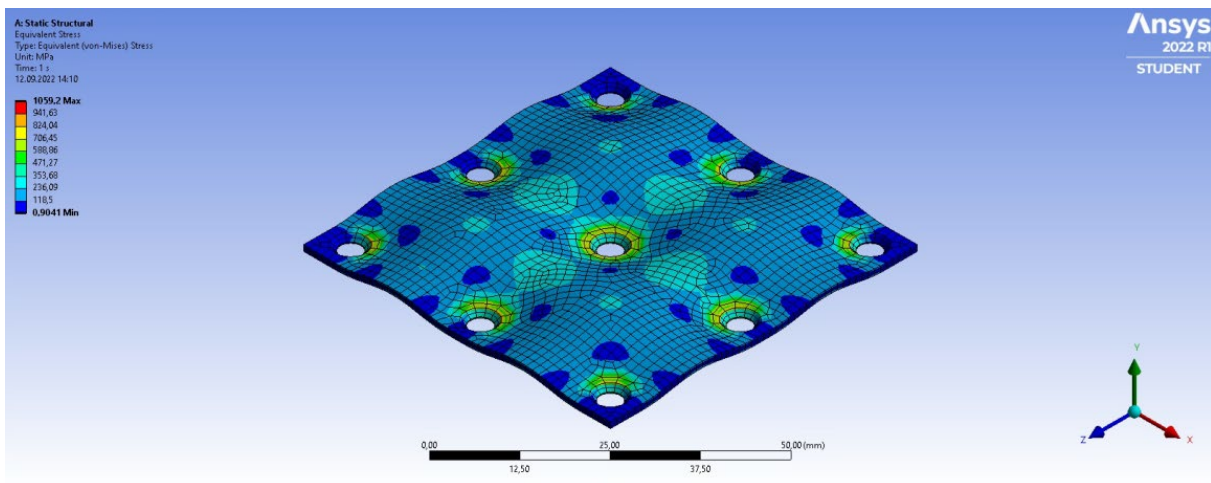

Figure 7: (a) the view of the meshed FE model of a sheet, and (b) the process of determination of the theoretical volume of corrosion products during appearance of the pilling effect



(a)



(b)

Figure 8: The exemplary results of numerical simulations for the analyzed sheet: (a) total deformation, (b) equivalent stress

Thickness of sheet (mm)	Corrosion severity (%)	Max. displacement (mm)	Max. stress (MPa)
1.14	5	0.352	1059
	10	0.705	2118
	15	1.057	3177
2.06	5	0.604	4561
	10	1.207	9122
	15	1.811	13684
3.66	5	0.996	11547
	10	1.992	23093
	15	2.988	34640

Table 1: The results of numerical simulations for determination hidden corrosion severity

From the obtained results, one can observe that the relationships between thickness and maximal displacement have linear character. This approach can be successfully used for the evaluation of the severity of the corrosion and its further correlation with the area of deformation, making it possible to develop the numerical tool for an evaluation of corrosion severity and prediction of its progression and resulting influence on a structural integrity.

4.2. Experimental Validation

In parallel to the numerical simulations, validation studies focusing on the assessment of accuracy of the D-Sight technique in the estimation of the geometrical properties of the deformations resulting from the pillowing effect. During these studies, two approaches were used: the classical metrology approach and the digital image correlation (DIC) technique.

The studies were carried out on sheets with artificially introduced dents of various depths in the range of 20-750 μm , which simulate the pillowing effect that appears during hidden corrosion. These dents were introduced with a CNC machine equipped with a special head designed for this purpose and equipped with the measurement system, providing the possibility to control the pushing force and the resulting deformation depth. The process of introducing artificial dents is presented in [Figure 9\(a\)](#). The specimens were then scanned using the DAIS 250C system to obtain D-Sight images for predefined deformations. The scanning process is presented in [Figure 9\(b\)](#).

The performed metrology approach assumed validation of the deformation height of the introduced deformation, which was performed using the coordinate measurement machine (see [Figure 10](#)). As a result of the performed preliminary measurements the accuracy of introducing deformation using the proposed approach is high, in general, however, some inaccuracies were observed for low values of deformation heights, especially for heights below 100 μm .

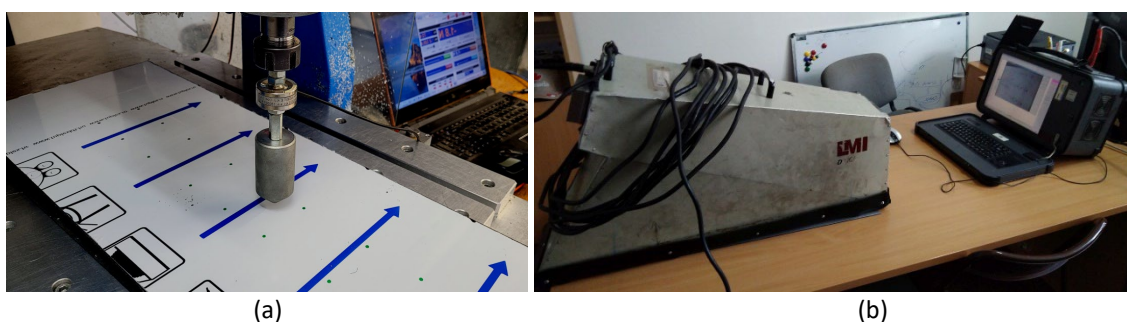
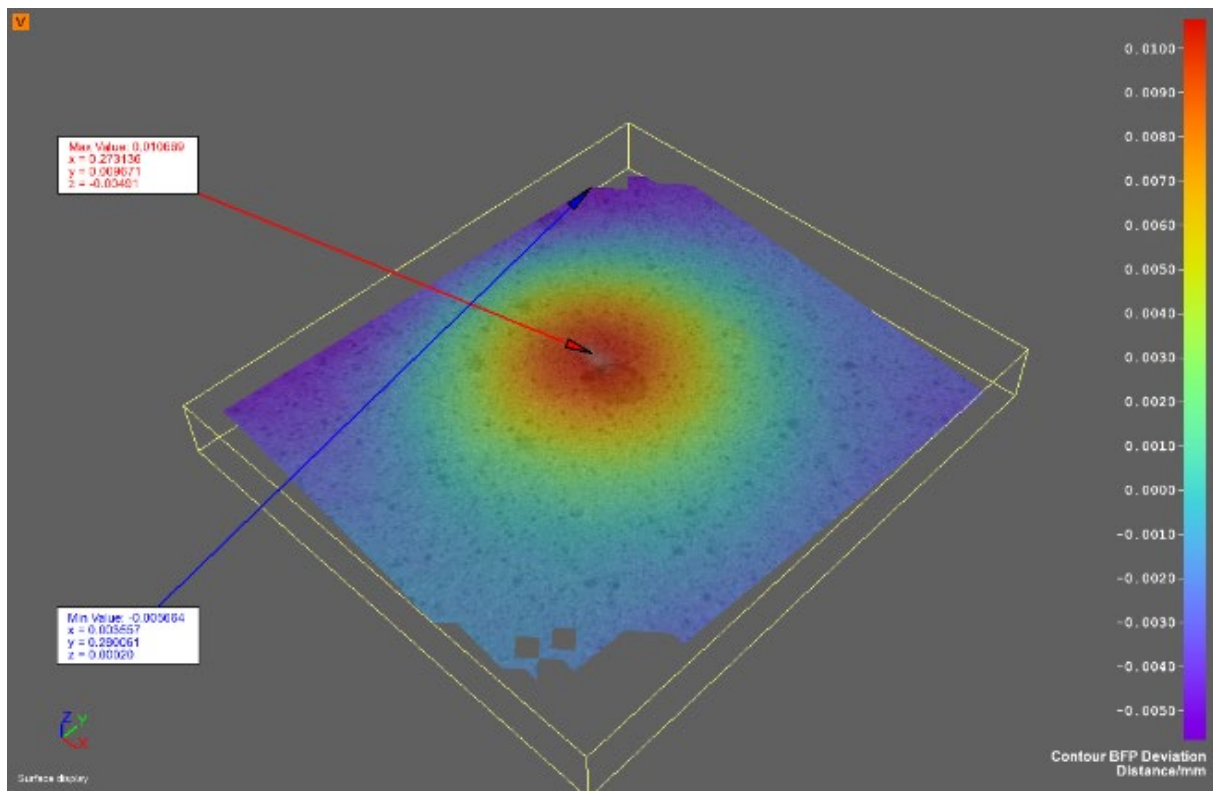

Figure 9: (a) the process of specimens preparation for validation tests, and (b) acquisition of D-Sight images

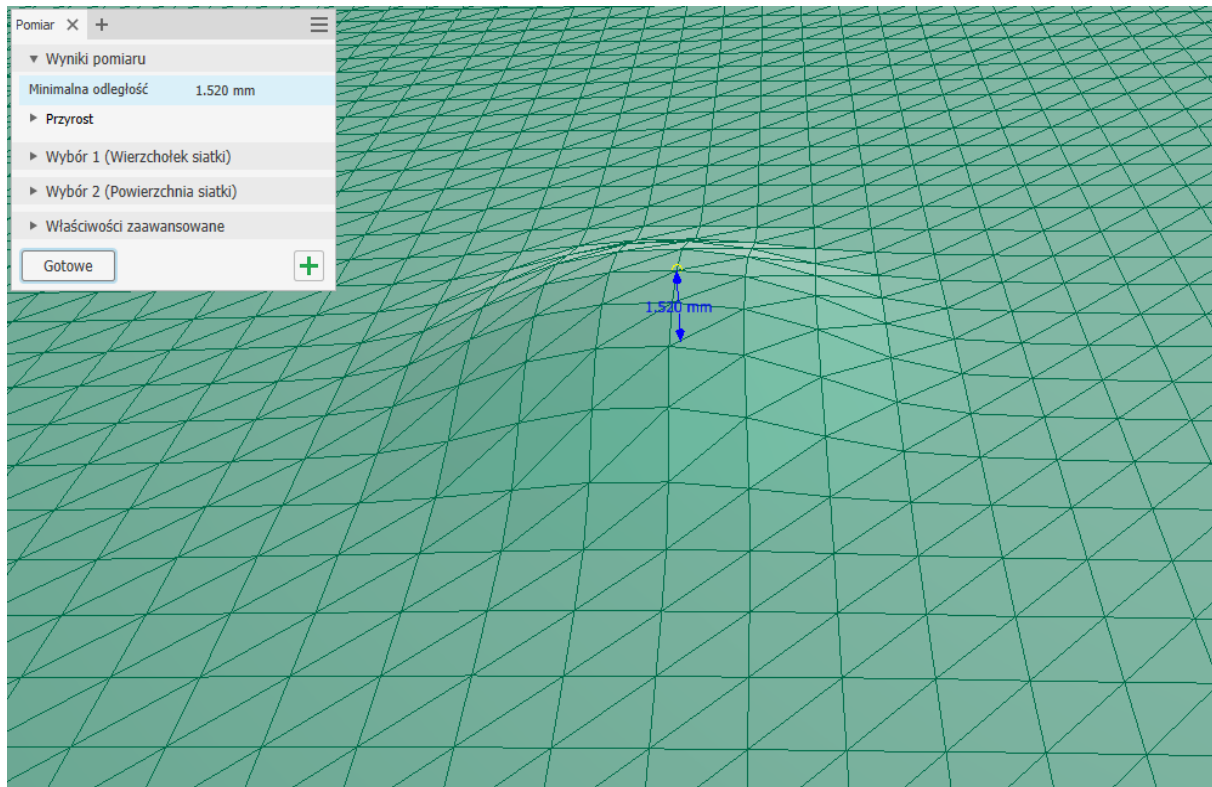

Figure 10: The process of measuring deformation heights using the coordinate measurement machine

The validation studies performed using DIC focused on evaluation of height and extent of introduced deformations. The exemplary results of the evaluation of measured deformations are presented in [Figure 11](#).



(a)



(b)

Figure 11: (a) the exemplary results of conditioning DIC measurements, (b) processing and evaluation of the DIC results

The evaluation was performed using the DIC system and dedicated software for this system, and further, the measurements were then exported to CATIA V5 commercial software in the form of points cloud, where it was transformed to the CAD models. Measurements were performed based on definition of a reference plane, from which the height and extent of a given deformation were measured. The preliminary measurements of the deformation height were in agreement with the measurement results obtained from the coordinate measurement machine. Moreover, they also demonstrated good agreement with the results obtained from processing of D-Sight images, which confirms the accuracy of quantification of hidden corrosion using the proposed approach.

4.3. Advancements in Quantification

The processing algorithm demonstrated in Section 3.2 was enhanced to automate the process of identification and quantification the corrosion spots. With the same pre-processing operations, the D-Sight images were subjected to further processing. For quantification, the pre-processed D-Sight images were converted in $L^*a^*b^*$ color space to reach the perceptual color uniformity, which was necessary for the calculation of ΔE^* local metric used for filtering the colors (Figure 12(a)). Next, the thresholding using Otsu's method was applied for a quantization of the achieved result (Figure 12(b)). After morphological operations that allowed to remove from the resulting image features attributed to rivets and edges of the image (Figure 12(c)), the mask with corrosion spots was created and superimposed on the pre-processed D-Sight image (Figure 12(d)).

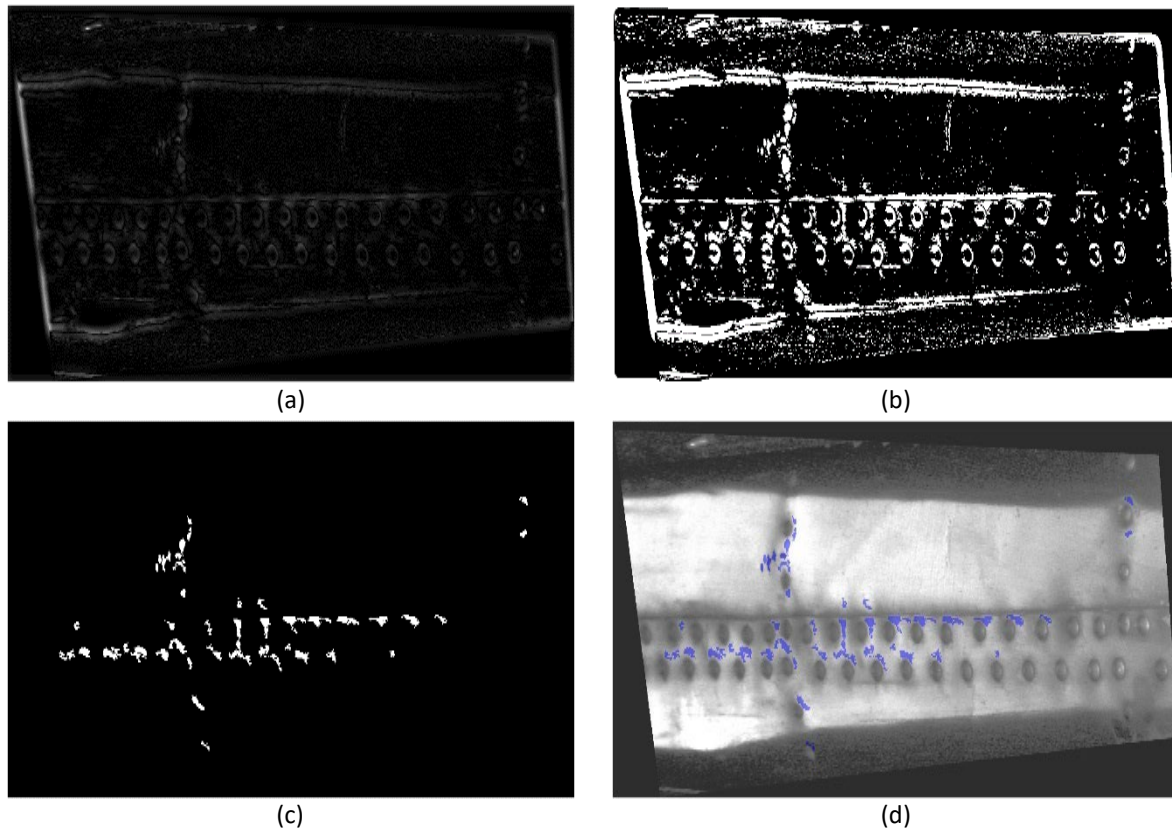

Figure 12: The steps of automated quantification of hidden corrosion spots on a D-Sight image: determination of the ΔE^* local metric (a), quantization using Otsu's method (b), application of morphological operations (c), visualizing the mask of quantified hidden corrosion on the pre-processed D-Sight image (d) (Katunin et al. 2023)

The presented processing algorithm was validated on D-Sight images captured during the inspection of Mil family military helicopters demonstrating good performance in automated quantification of the hidden corrosion spots (Katunin et al. 2023).

5. Conclusions and Further Research Directions

The following study presents the initially verified concept of enhancement of the D-Sight NDT technique. This enhancement focuses on making the quantitative analysis possible using this technique, which has significant implications in practical applications, primarily, in supporting NDT inspectors and data scientists working with inspection results in evaluation of hidden corrosion in aircraft structures. Research on improving the D-Sight technique is currently ongoing, and the following paper presents recent advances towards quantification of hidden corrosion in aircraft structures.

The performed preliminary studies show the possibility to enhance the D-Sight NDT technique and make it quantitative, i.e., using the proposed algorithms of processing raw D-Sight images and with support of numerical modeling, it is possible to determine dimensions of the corrosion spot, both planar and in the direction of the thickness of a tested structure. The evaluation results using the proposed approach were initially validated using reference methods, and a comparative study revealed a good coincidence, which additionally confirms the sufficient sensitivity of the D-Sight technique in the detection and quantification of even hidden corrosion spots, when deformation height is below 100 μm .

The promising initial results make it possible to draw further research directions:

- The developed processing algorithm is planned to be improved by developing more effective methods of evaluation of the corrosion extent to make it possible to compare whole D-Sight images by finding common points in the sequence of historical data. It is also planned to perform further automation of the processing algorithm, primarily in terms of segmentation and estimation of true dimensions of the corrosion spots.
- The initial validation studies using reference techniques need to be repeated in a systematic research to evaluate the accuracy of the D-Sight technique in the estimation of dimensions of hidden corrosion spots with statistical analysis to justify the validity of acquired results using the developed processing algorithm.

References

- Sayedi, S. and Q. Huang. 2019. "Reliability-based life-cycle-cost comparison of different corrosion management strategies", *Engineering Structures* 186:52-63. DOI: [10.1016/j.engstruct.2019.02.018](https://doi.org/10.1016/j.engstruct.2019.02.018).
- Benavides, S. 2009. "Corrosion in aerospace industry". In *Corrosion Control in the Aerospace Industry*, 1-14. Cambridge: Woodhead Publishing. DOI: [10.1533/9781845695538.1](https://doi.org/10.1533/9781845695538.1).
- Nechval, N., K. Nechval, M. Purgailis and V. Strelchonok. 2011. "Planning inspections in the case of damage tolerance approach to service of fatigued aircraft structures", *International Journal of Performability Engineering* 7:279-290. DOI: [10.23940/ijpe.11.3.p279.mag](https://doi.org/10.23940/ijpe.11.3.p279.mag).
- Grandt Jr., F. 2011. "Damage tolerant design and nondestructive inspection - Keys to aircraft airworthiness", *Procedia Engineering* 17:236-246. DOI: [10.1016/j.proeng.2011.10.025](https://doi.org/10.1016/j.proeng.2011.10.025).
- FAA – Federal Aviation Administration. 1998. "Acceptable methods, techniques, and practices – aircraft inspection and repair", AC 43.13-1b. https://www.faa.gov/documentlibrary/media/advisory_circular/ac_43.13-1b_w-chg1.pdf.
- Wronkowicz-Katunin, A. 2018. "A brief review on NDT&E methods for structural aircraft components", *Fatigue of Aircraft Structures* 2018:73-81. DOI: [10.2478/fas-2018-0007](https://doi.org/10.2478/fas-2018-0007).
- Towsyfyan, H., A. Biguri, R. Boardman and T. Blumensath. 2020. "Successes and challenges in non-destructive testing of aircraft composite structures", *Chinese Journal of Aeronautics* 33:771-791. DOI: [10.1016/j.cja.2019.09.017](https://doi.org/10.1016/j.cja.2019.09.017).
- Mills, T., S. Prost-Domasky, K. Honeycutt and C. Brooks. 2009. "Corrosion and the threat to aircraft structural integrity". In *Corrosion Control in the Aerospace Industry*, 35-66. Cambridge: Woodhead Publishing. DOI: [10.1533/9781845695538.1.35](https://doi.org/10.1533/9781845695538.1.35).
- Czaban, M. 2018. "Aircraft corrosion – review of corrosion processes and its effects in selected cases", *Fatigue of Aircraft Structures* 2018:5-20. DOI: [10.2478/fas-2018-0001](https://doi.org/10.2478/fas-2018-0001).
- Katunin, A. 2019. *Aircraft Structures. Mechanics, Design, and Maintenance*, Gliwice: Silesian University of Technology Press.
- Bellinger, N.C., J.P. Komorowski and R.W. Gould. 2007. "Corrosion pillowing in aircraft fuselage lap joints", *Journal of Aircraft* 44:758-763. DOI: [10.2514/1.18589](https://doi.org/10.2514/1.18589).
- Forsyth, D. and B. Lepine. 2002. "Development and verification of NDI for corrosion detection and quantification in airframe structures", *AIP Conference Proceedings* 615:1787. DOI: [10.1063/1.1473009](https://doi.org/10.1063/1.1473009).
- Agarwala, V.S. and S. Ahmad. 2000. "Corrosion detection and monitoring – A review". In *Proceedings of the NACE CORROSION*, Orlando, FL, USA. 00271.
- Kant, R., P.S. Chauhan, G. Bhatt and S. Bhattacharya. 2019. "Corrosion monitoring and control in aircraft: A review". In *Sensors for Automotive and Aerospace Applications*, 39-53. Singapore: Springer. DOI: [10.1007/978-981-13-3290-6_3](https://doi.org/10.1007/978-981-13-3290-6_3).

- Ciężak, P. and A. Rdzanek. 2020. "Corrosion monitoring of aircraft based on the corrosion prognostic health measurement (CPHM) system", *Journal of KONBIN* 50: 205-216. DOI: [10.2478/jok-2020-0082](https://doi.org/10.2478/jok-2020-0082).
- Hegeniers, O. 1993. "D SIGHT for large area aircraft inspection", *Proceedings of SPIE* 2001: 248-256. DOI: [10.1117/12.163848](https://doi.org/10.1117/12.163848).
- Komorowski, J.P. and N.C. Bellinger, R.W. Gould. 1997. "The role of corrosion pillowing in NDI and in the structural integrity of fuselage joints". In *Proceedings of the 19th Symposium of the International Committee on Aeronautical Fatigue*, 251-266. Edinburgh.
- Katunin, A., M. Nagode, S. Oman, A. Cholewa and K. Dragan. 2022. "Monitoring of hidden corrosion growth in aircraft structures based on D-Sight inspections and image processing", *Sensors* 22:7616. DOI: [10.3390/s22197616](https://doi.org/10.3390/s22197616).
- Reynolds, R.L., F. Karpala, D.A. Clarke and O.L. Hegeniers. 1993. "Theory and applications of a surface inspection technique using double-pass retroreflection", *Optical Engineering* 32: 2122-2129. DOI: [10.1117/12.143938](https://doi.org/10.1117/12.143938).
- Bellinger, N., J. Komorowski and T. Benak. 2001. "Residual life predictions of corroded fuselage lap joints", *International Journal of Fatigue* 23: 349-356. DOI: [10.1016/S0142-1123\(01\)00148-7](https://doi.org/10.1016/S0142-1123(01)00148-7).
- Katunin, A. and K. Dragan. 2022. "Qualitative to quantitative non-destructive evaluation: A concept for D-Sight inspections of aircraft structures", *Applied Mechanics and Materials* 909: 69-74. DOI: [10.4028/p-d8r1x7](https://doi.org/10.4028/p-d8r1x7).
- Komorowski, J.P., N.C. Bellinger, R.W. Gould, A. Marincak and R. Reynolds. 1996. "Quantification of corrosion in aircraft structures with double pass retroreflection", *Canadian Aeronautics and Space Journal* 42: 76-82.
- Katunin, A., K. Lis, K. Jozsko, P. Żak and K. Dragan. 2023. "Quantification of hidden corrosion in aircraft structures using enhanced D-Sight NDT technique", *Measurement* 216:112977. DOI: [10.1016/j.measurement.2023.112977](https://doi.org/10.1016/j.measurement.2023.112977).
- Heida, J. and A. Bruinsma. 1998. "D-Sight technique for rapid impact damage detection on composite aircraft structures". In *Proceedings of the 7th European Conference on Non-destructive Testing*. Copenhagen: NDT.net.
- Leski, A., S. Klimaszewski, K. Dragan and M. Kudelski. 2006. „Aircraft structural integrity program of Polish Su-22 'Fitter' aircraft". In *Proceedings of the 2006 USAF Structural Integrity Program (ASIP) Conference*. San Antonio, TX.
- Nagode, M., B. Panić, J. Klemenc and S. Oman. 2022. "Rebmix: Finite Mixture Modeling, Clustering & Classification", R Package Version 2.14.2, available online: <https://cran.r-project.org/web/packages/rebmix/rebmix.pdf> (accessed on March 22nd, 2023).
- Bellinger, N.C. and J.P. Komorowski. 1997. "Corrosion pillowing stresses in fuselage lap joints", *AIAA Journal* 35:317-320. DOI: [10.2514/2.94](https://doi.org/10.2514/2.94).
- Żak, P. 2022. "Ocena wykrywania korozji w elementach lotniczych na podstawie symulacji numerycznej odkształceń" [Evaluation of corrosion detection in aircraft elements based on numerical simulation of deformations]. Master's thesis, Silesian University of Technology.
- Katunin, A., P. Synaszko, K. Dragan. 2023. "Automated identification of hidden corrosion based on D-Sight technique: A case study on a military helicopter", *Sensors* 23:7131. DOI: [10.3390/s23167131](https://doi.org/10.3390/s23167131).

Acknowledgments

This study was supported under the Excellence Initiative – Research University program implemented at the Silesian University of Technology, year 2021, grant. no. 10/060/SDU/10-21-01; and the program (Nr. P2-0182) entitled Development evaluation financed by the Slovenian Research Agency.